

Model : UTE

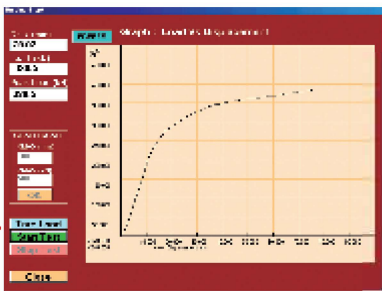

Real time graph on PC

**\* With PC Interface & Real Time Graph.  
( Panel / PC Controlled )**

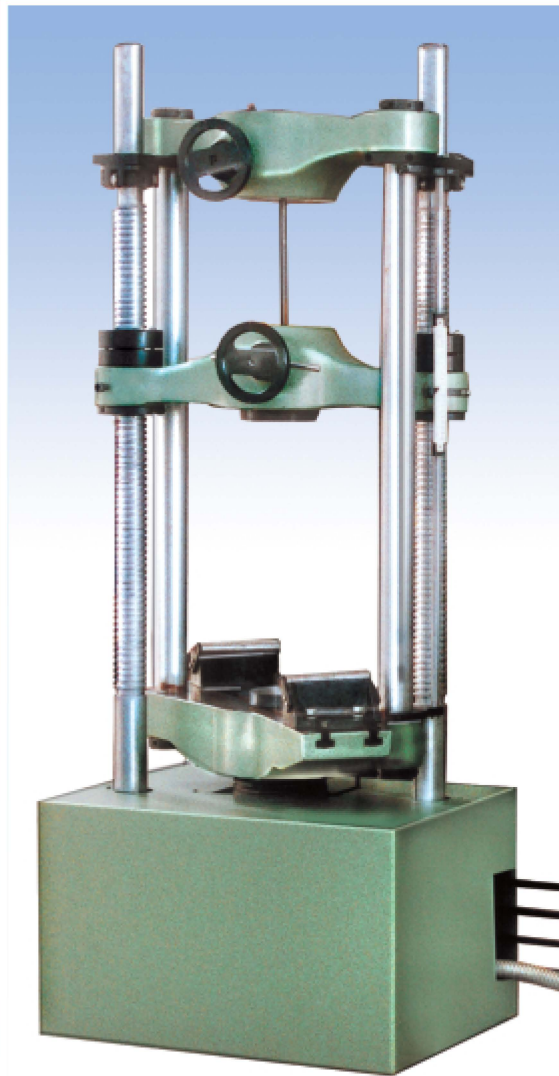
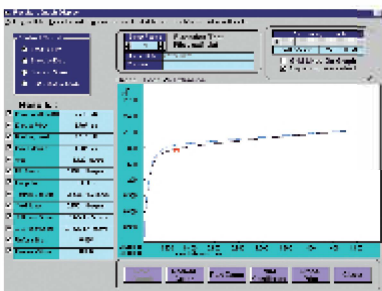

Graph comparison & point tracing.



Statistics

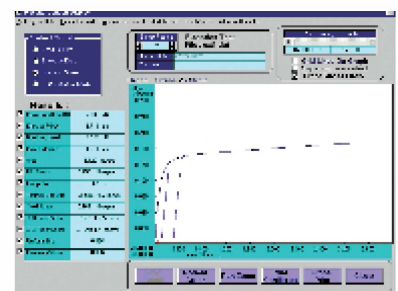

Graph with EE2 extensometer.

- Loading accuracy as high  $\pm 1\%$ .
- Straining at variable speeds to suit a wide range of materials.
- Printer & PC graphs enable study the behavior of the material.
- Motor driven threaded columns for quick effortless adjustment of middle crosshead to facilitate rapid fixing of test specimen.
- Simplicity in reading because of digital readouts.
- Wide range of standard and special accessories, including load stabilizer.
- Easy change from plain to threaded and screwed specimens.
- Large effective clearance between columns enable testing of standard specimens as well as structures.
- Simple controls for ease of operation.
- Robust straining frame of an extremely rigid construction.
- Safe operation ensured by means of safely devices.
- Fully enclosed and protected pressure transducer.
- RS 232 serial port to transfer data to computer for analysis/storage evaluation etc.
- Manual control & release valve operation.



**ATTACHMENT FOR TENSION TEST FOR SHOULDERED AND THREADED SPECIMENS**

### Application :

FIE Electronic Universal Testing Machine is designed for testing metals and other materials under tension, compression, bending, transverse and shear loads. Hardness test on metals can also conducted.

### Principle of Operation :

Operation of the machine is by hydraulic transmission of load from the test specimen through pressure transducer to a separately house load indicator. The system is ideal since it replaces transmission of load through levers and knife edges, which are prone to wear and damage due to shock on rupture of test pieces.

Load is applied by hydrostatically lubricated ram. Main cylinder pressure is transmitted to the pressure transducer housed in the control panel. The transducer gives the signal to the electronic display unit, corresponding to the load exerted by the main ram. Simultaneously the digital electronic fitted on the straining unit gives the mechanical displacement to the electronic display unit. Both the signals are processed by the microprocessor and load and displacement is displayed on the digital readouts simultaneously.

Machine consists of :

### Straining Unit :

This consists of a cylinder motor with chain & sprocket drive and a table coupled with the ram of the hydraulic cylinder, mounted on to a robust base. The cylinder and the ram are individually lapped to eliminate friction. The upper cross-head is rigidly fixed to the table by two strengthened columns.

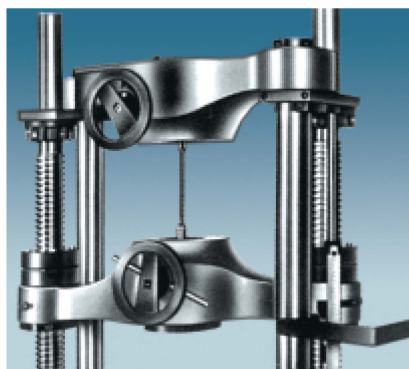

**TENSION TEST**

The lower cross-head is connected to two screwed columns which are driven by a motor. Axial loading of the ram is ensured by relieving the cylinder and ram of any possible side loading by the provision of ball seating.

An displacement scale with a minimum graduation of 1mm, is provided to measure the deformation of the specimen.

Tension test is conducted by gripping the test specimen between the upper and lower cross-heads.

Compression, transvers, bending, shear & hardness tests are conducted between the lower cross-head and the table.

The lower cross-head can be raised or lowered rapidly by operating the screwed columns, thus facilitating ease of fixing of the test specimen.

### Control Panel :

The control panel consists of a power pack complete with drive motor and an oil tank, control valves and electronic display unit.

### Power Pack :

The power pack generates the maximum pressure of 200 kgf/cm<sup>2</sup>. The hydraulic pump provides continuously non-pulsating oil flow. Hence the load application is very smooth.

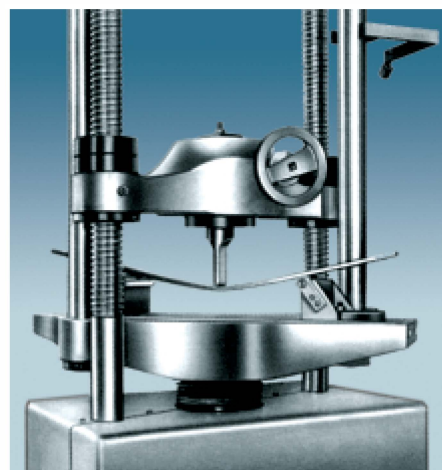

**TRANSVERSE TEST**

## Hydraulic Controls :

Hand operated wheels are used to control the flow to and from the hydraulic cylinder. The regulation of the oil flow is infinitely variable. Incorporated in the hydraulic system is a regulating valve, which maintains a practically constant rate of piston movement. Control by this valve allows extensometer reading to be taken.

## Electronic Control Panel (Series Universal 2001-UTE) :

Microprocessor based panel incorporating state of art technology with following features.

Front panel membrane type key board for machine operation with numeric keys for data entry.

7 segment display.

Data entry with numeric keyboard of test parameters including speeds, rupture % peak, preload, modulus data, test data & specimen data etc.

20 input data set storage, 50 results storage, maintains data & results during power off.

Batch test facility for generating batch & statistics result. using same data set.

RS 232C serial port. Optional windows based software available for ...

On line graph on PC. Data analysis, statistics, point tracing superimposing graphs to compare with standard, zooming graph etc.

Printer port for printer interface with ...

- Graph & result printout. Test certificate printout.
- Batch Certificate printout.
- Simple statistics printout.



**ATTACHMENT FOR TENSION TEST FOR WIRE ROPES**

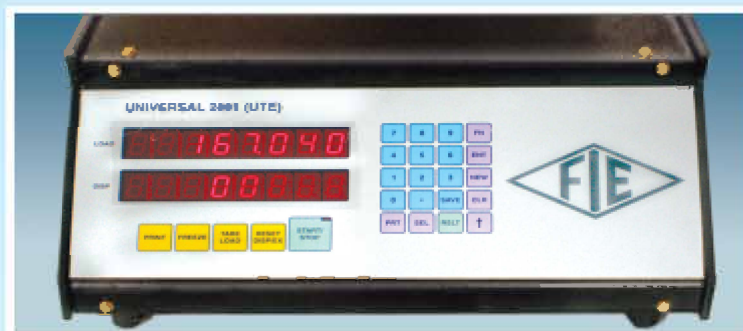

## Opional Software packages on PC :

The UINIVERSAL 2001 - UTE series control panel can be hooked to any PC using RS-232 communication port. FIE offers different exhaustive application, Window based software packages with real time graph on PC to enable the user to effectively evaluated different parameters. The features include :

- Real time graph, User friendly software.
- Extensive graphics on screen for curve plotting, magnification and zooming.
- Software features includes Graph comparison, point tracing facility. Different units selection for load & displacement.
- Statistical evaluation with water fall dig., Mean deviation, frequency distribution, Skew dig., Histogram. Also calculates max. value, min. value, Mean Value, Variance, Standard Deviation. (Other statistical parameters on request). Selectable batch & statistical printouts.
- Evaluation of wide range of user selectable parameters such as % elongation, % reduction in area, young's modulus, yield stress, proof stress etc.
- Software packages for Shear, Bend, Torsion, Rubber, Textile testing etc.
- Custom built application software to suit customer requirements.

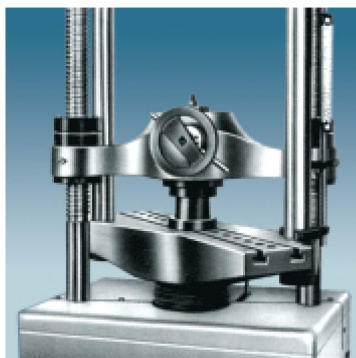

**COMPRESSION TEST**

## Accuracy and Calibration :

All FIE Electronic Universal Testing Machines are closely controlled for sensitivity, accuracy and calibration during every stage of manufacture. Every machine is then calibrated over each of its measuring ranges in accordance with the procedure laid down in British standards. 1610 : Part 1 : 1992 and IS : 1828 : Part 1 : 1991.

FIE Electronic Universal Testing Machine comply with Grade "A" of BS:1610:Part 1:1992 and class 1 of IS-1828-Part 1:1991. An accuracy of  $\pm 1\%$  is guaranteed from 2% to 100% of the capacity of the machine.

Below 20% of the selected range, the maximum permissible error is 0.2% of the full load reading.

**UTE Panel/PC Controlled Machine, Servo Controlled Model available.**

**It is with motorised control valve & automatic operation with given loading/elongation rate.**



| MODEL  | UNITS  | UTE-10                    | UTE-20                    | UTE-40                    | UTE-60                    | UTE-100                   | UTE-200                    | UTE-300                    |
|--|--------|---------------------------|---------------------------|---------------------------|---------------------------|---------------------------|----------------------------|----------------------------|
| Maximum Capacity   | kN     | 100                       | 200                       | 400                       | 600                       | 1000                      | 2000                       | 3000                       |
| Measuring Range  | kN     | 0-100                     | 0-200                     | 0-400                     | 0-600                     | 0-1000                    | 0-2000                     | 0-3000                     |
| Load Resolution<br>(20,000 counts full scale)                        | N      | 5                         | 10                        | 20                        | 30                        | 50                        | 100                        | 150                        |
| Load Range with Accuracy of<br>measurement $\pm$ 1.0%                | kN     | 2 to 100                  | 4 to 200                  | 8 to 400                  | 12 to 600                 | 20 to 1000                | 40 to 2000                 | 60 to 3000                 |
| Resolution of piston movement<br>(Displacement)                      | mm     | 0.1                       | 0.1                       | 0.1                       | 0.1                       | 0.1                       | 0.1                        | 0.1                        |
| Clearance for tensile at<br>fully descended working piston.          | mm     | 50-700                    | 50-700                    | 50-700                    | 50-800                    | 50-850                    | 50-900                     | 50-900                     |
| Clearance for compression test at<br>fully descended working piston. | mm     | 0-700                     | 0-700                     | 0-700                     | 0-800                     | 0-850                     | 0-900                      | 0-900                      |
| Clearance between columns.   | mm     | 500                       | 500                       | 500                       | 600                       | 750                       | 850                        | 850                        |
| Ram Stroke   | mm     | 150                       | 200                       | 200                       | 250                       | 250                       | 300                        | 300                        |
| Straining/piston speed (at no load)                                  | mm/min | 0-300                     | 0-150                     | 0-150                     | 0-100                     | 0-80                      | 0-45                       | 0-50                       |
| <b>CONNECTED LOAD</b>  |        |                           |                           |                           |                           |                           |                            |                            |
| Power  | kW     | 1.0                       | 1.0                       | 1.7                       | 1.9                       | 2.6                       | 4.9                        | 6.4                        |
| V  |        | 400-440                   | 400-440                   | 400-440                   | 400-440                   | 400-440                   | 400-440                    | 400-440                    |
| Ø  |        | 3                         | 3                         | 3                         | 3                         | 3                         | 3                          | 3                          |
| <b>DIMENSIONS</b>  |        |                           |                           |                           |                           |                           |                            |                            |
| LxWxH (approx.)  | mm     | 2032 x<br>750 x<br>1960 x | 2032 x<br>750 x<br>1960 x | 2060 x<br>750 x<br>2180 x | 2265 x<br>750 x<br>2534 x | 2415 x<br>815 x<br>2900 x | 3000 x<br>1200 x<br>3600 x | 3500 x<br>1900 x<br>4550 x |
| WEIGHT (approx.)   | kg.    | 1500                      | 1500                      | 2500                      | 3500                      | 5500                      | 9500                       | 15,000                     |
| <b>STANDARD ACCESSORIES</b>  |        |                           |                           |                           |                           |                           |                            |                            |
| <b>FOR TENSION TEST</b>  |        |                           |                           |                           |                           |                           |                            |                            |
| ● Clamping jaws for round<br>specimens of Diameters.                 | mm     | 10-20<br>20-30            | 10-20<br>20-30            | 10-25<br>25-40            | 10-25<br>25-40<br>40-55   | 10-25<br>25-45<br>45-70   | 20-40<br>40-60<br>60-80    | 25-50<br>50-70<br>70-90    |
| ● Clamping jaws for flat<br>specimens of thickness.                  | mm     | 0-10<br>10-20             | 0-10<br>10-20             | 0-15<br>15-30             | 0-15<br>15-30             | 0-22<br>22-44<br>44-65    | 0-20<br>20-45<br>45-70     | 0-25<br>25-50<br>50-75     |
| Width  | mm     | 50                        | 50                        | 65                        | 70                        | 70                        | 90                         | 100                        |
| <b>FOR COMPRESSION TEST</b>  |        |                           |                           |                           |                           |                           |                            |                            |
| Pair of compression plates of dia.                                   | mm     | 120                       | 120                       | 120                       | 120                       | 160                       | 220                        | 220                        |
| <b>FOR TRANSVERSE TEST</b>   |        |                           |                           |                           |                           |                           |                            |                            |
| Table with adjustable rollers<br>width of rollers.                   | mm     | 160                       | 160                       | 160                       | 160                       | 160                       | 200                        | 200                        |
| Diameter of Rollers  | mm     | 30                        | 30                        | 30                        | 50                        | 50                        | 70                         | 70                         |
| Maximum clearance between<br>supports                                | mm     | 500                       | 500                       | 500                       | 600                       | 800                       | 900                        | 1000                       |
| Radius of punch tops.  | mm     | 6,12                      | 6,12                      | 12,16                     | 16,22                     | 16,22                     | 30,40                      | 50,75                      |

#### SPECIAL ACCESSORIES & OPTIONS :

- Load Stabilizer
- Printer
- Plotter
- Brinell test attachment
- Electronic extensometer
- Piston movement resolution of 0.01mm
- Electronic load pacer
- Shear test attachment
- Software packages
- Mechanical extensometer

- Wide range accessories offered on request at additional cost.
- Due to constant R & D specifications & features are subject to change without notice.
- The dimensions given above are approximate.

\* PC & Printer is not in our standard scope of supply.

# CANAN TESTING SERVICES

Accredited by NABL (Dept. of Science & Technology-Govt. of India)

11, 1st Floor, Convenient Shopping Centre, Pocket-F, G.T.B Enclave, Nand Nagari, Delhi - 110093

Tel : +91-11-22580160 | +91-11-22583460 | +91-11-2594094

E-mail : [canan@canantesting.com](mailto:canan@canantesting.com)

Web : [www.canantesting.com](http://www.canantesting.com)